



FORWARD-THINKING LINE-ARRAY DESIGN

# X-LINE ADVANCE

VERTICAL LINE-ARRAY LOUDSPEAKER SYSTEMS GUIDE



Headquarters Americas:  
Bosch Security Systems, Inc.  
12000 Portland Ave South | Burnsville, MN 55337 | USA  
Ph: 1 800 289 0096 | Fax: 1 800 955 6831  
[buv.orders@us.bosch.com](mailto:buv.orders@us.bosch.com)



X-LINEADVANCE

# ADVANCING THE STATE OF SOUND REINFORCEMENT

A driving force in concert sound reinforcement since its beginning, EV is dedicated to developing products that exceed the ever-higher expectations of audiences, performers, and production professionals the world over. We channel our industry-leading engineering experience and R&D resources towards product designs that push the art and science of sound forward, rather than following the pack.

To achieve our goal of creating a line array with the best acoustic and mechanical performance, we talked to dozens of touring professionals and combined their real-world insight with our decades of line-array know-how.

The result is the next generation of our legendary X-Line family, offering breakthrough new components that work together to surpass the performance of other competitive line arrays, and all in a more compact, flexible, and faster-to-set-up package.

Designed, engineered, and tested for ultimate reliability by Electro-Voice in the USA.

## Table of Contents

System Concept	3-4
X1 System Applications	5
X2 System Applications	6
X1-212/90	7-8
X2-212/90	9-10
X12-128 Ground-stack Subwoofer	11-12
Rigging	13-14
Grids and Rigging Systems	15-16
Transport Systems	17-18
Line Array Prediction Software (LAPS 3)	19-20
Electronics	21-22
IRIS-NET	23-24

---

## System Configurations

X1 Passive 1/4 System	25
X1 or X2 Bi-amp 1/4 System	26
X1 or X2 1/4 System with TOPS Expansion	27
X1 or X2 Bi-amp 1/2 System	28
X1 or X2 Bi-amp 3/4 System	29
X1 or X2 Bi-amp Full System	30

# System Concept

# System Concept

**Only a matched system will produce the best-possible sound quality.**

X-Line Advance is more than just a line-array loudspeaker family for small-to-medium scale fixed installation and live sound reinforcement. Instead of simply setting out to design some new speakers, we took our time and developed a completely integrated system combining new high-performance components, innovative enclosure and hardware, powerful signal processing, and advanced software control that is designed to guarantee the highest possible acoustical and mechanical performance.

The OMNEO media networking architecture, the all-new LAPS 3 Line-Array Prediction Software, and the IRIS-Net software environment are key Electro-Voice technologies that contribute to an X-Line Advance system's flexibility, fast and easy setup, and sound tailored for the components in the speakers. The individual loudspeaker drivers, Hydra plane-wave generators, acoustic waveguides, enclosures, and rigging hardware were also designed for the X1 and X2 product line to not only achieve the highest acoustic output with the highest fidelity, but also to produce a precise wavefront from each element — all working together to advance the state of high-end sound reinforcement.

For applications where additional low-frequency output is required, the X12-128 subwoofer adds to the X-Line Advance's flexibility with a design that simplifies system scalability and efficient configuration for full-bandwidth coverage in any venue.

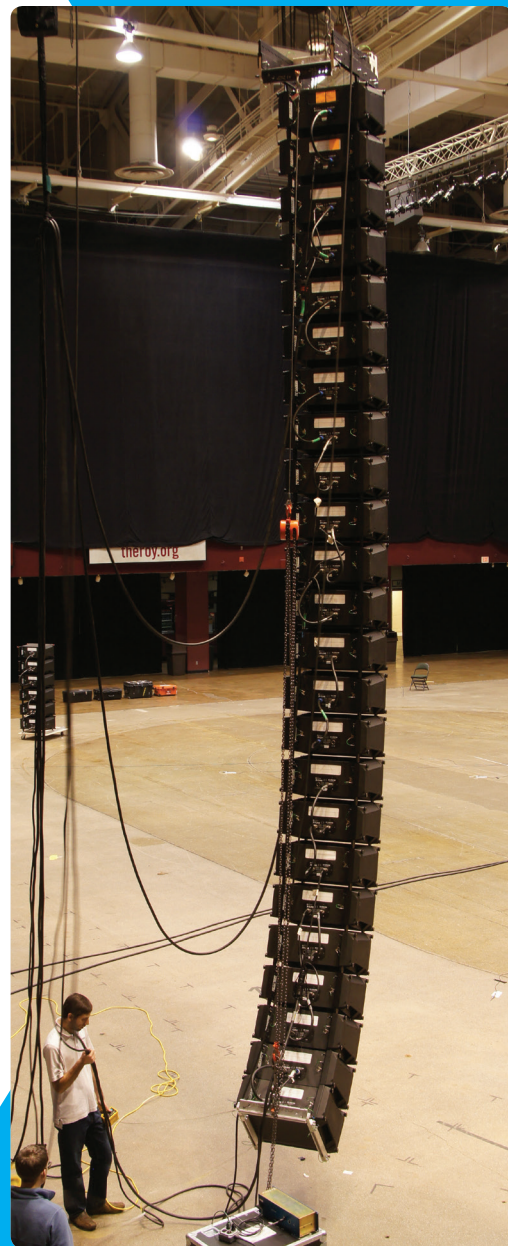

Acoustics



Amplification



Signal Processing & System Control



“ INTERDISCIPLINARY EXPERTISE IN ACOUSTICS, AMPLIFICATION, SIGNAL PROCESSING & SYSTEM CONTROL IS THE ONLY WAY TO GUARANTEE OPTIMUM SOUND. ”

X-LINEADVANCE

# XONE System Applications

## Fixed Installation

The X1-212/90 combines new EV acoustic and driver technology with outstanding value to deliver a compact line array solution for many installation venues. Its compact footprint is ideally suited for small and mid-sized spaces, especially where limited space is available for a sound reinforcement solution.

Its ability to operate in passive mode with its internal high-performance crossover network reduces the overall system cost and simplifies the installation in these applications.

The X1: performance combined with simplicity and value.



## X1

An ideal choice for...

- SMALL AND MID-SIZED HOUSES OF WORSHIP
- LOCAL AND REGIONAL AV RENTAL COMPANIES
- CORPORATE EVENTS
- CLUBS AND ENTERTAINMENT VENUES

X-LINEADVANCE

# XTWO System Applications

## Live Sound and Touring

The X2-212/90 is a premium solution for demanding live sound reinforcement and fixed-install applications. The X2 is a two-way vertical line-array loudspeaker that can be used in a wide variety of applications where wide bandwidth, vertical and horizontal directivity control, and high efficiency are required in a compact, cost-effective package.

The bi-amp only X2 requires proprietary Electro-Voice FIR-Drive. FIR-Drive is the combination of brick wall crossovers, phase correction, finite impulse response (FIR) equalization filters, peak anticipation limiting, and thermal monitoring. These technologies yield superior, nearly inaudible transducer protection, with linear summation, smooth off-axis response, and unparalleled acoustical performance over the critical vocal and instrument ranges, regardless of array size.

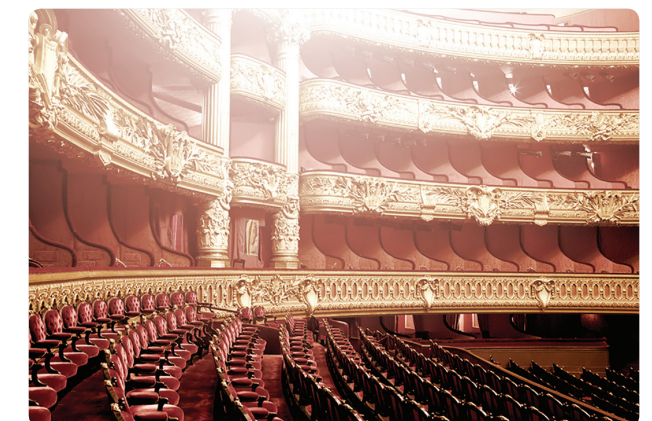

## X2

Delivers the SPL, bandwidth, and coverage needed for demanding applications, including...

- LARGE HOUSES OF WORSHIP
- CONCERT AND TOUR SOUND EVENTS
- SPORTS VENUES
- THEATERS AND PERFORMING ARTS VENUES

# XONE X1-212/90

# XONE X1-212/90

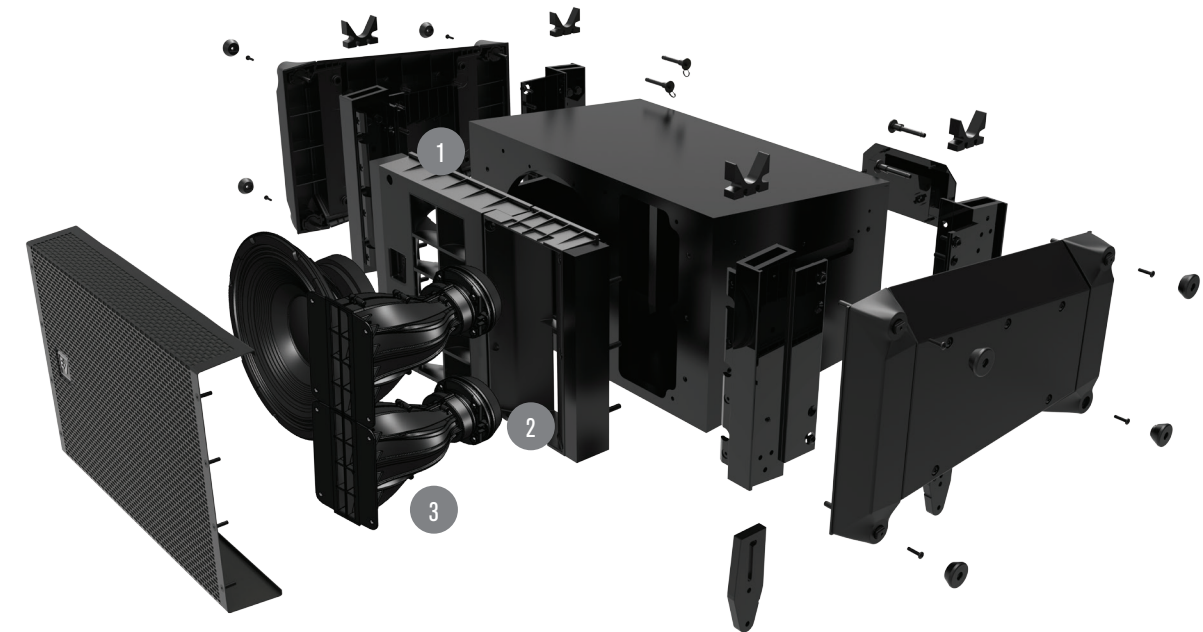

The X1-212/90 system combines innovative new technologies and time-saving features. The compact design of the X1 enables its use in a wide variety of applications.

The X1 is a two-way vertical line-array loudspeaker that can be used in a wide variety of applications where wide bandwidth, vertical and horizontal directivity control, and high efficiency are required in a compact, cost-effective package.

In passive mode, it is possible to configure X1 so that up to three elements are powered from a single amplifier channel, the necessary crossover and EQ functions accomplished with sophisticated internal passive networks. X1 can also operate in bi-amp mode.

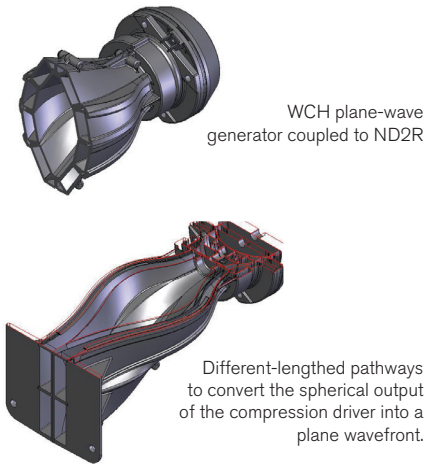

### X1 Plane-Wave Creation

EV's new Wavefront-shaping Circular Hydra (WCH) design in the X1 mates with the newly designed ring-exit ND2R driver to provide a linear frequency output that extends beyond 16 kHz. The outward-curving channels in the Hydra align precisely with the driver exit to transfer acoustical energy more efficiently and shape the acoustic wave more precisely than previous designs. This combination delivers an extended, smooth HF output. When combined, this new circular Hydra and ring-exit ND2R combination deliver amazing performance in the medium-format HF driver class.

SPECIFICATIONS	X1-212/90
Frequency Response (-3 dB):	57 Hz – 16 kHz
Horizontal Coverage:	90° horizontal
System Sensitivity:	98 dB (1 W/1 m)
LF Transducer:	12" SMX2121
HF Transducer:	Two 2" ND2R
Configuration:	Passive, bi-amp
Enclosure Material:	EVCoat-coated birch plywood
Dimensions (H x W x D):	13.5" x 28.5" x 21.125" (34.29 cm x 72.39 cm x 53.66 cm)
Net Weight:	92 lbs (41.73 kg)

### 1 Mid-Band Hydra (MBH)

The 12" SMX woofer in the X1 is coupled to an EV-exclusive MBH device that effectively emulates the acoustic behavior of a double line of four 3" point sources to deliver superior mid-band coupling of the array while maintaining the efficiency, power, and bandwidth of a 12" transducer.

### 2 ND2R High-Frequency Driver

The ND2R is a new version of the ND2 compression driver. Its ring-shaped exit achieves more balanced energy input to the WCH, with extended high end and lower distortion compared to the current ND2.

### 3 Wavefront-Shaping Circular Hydra (WCH)

The revolutionary HF section in the X1 incorporates two new ND2R ring-exit high-output 2" titanium compression drivers coupled to a pair of WCH constant energy plane-wave generators on a waveguide optimized for high efficiency, uniform pattern control, and smooth, extended, linear response. The ring-coupled ND2R and WCH eliminate wave distortion, maximizing the acoustic output of this medium-format compression driver with in-phase summation past 16 kHz.

X-LINEADVANCE

# XTWO X2-212/90

X-LINEADVANCE

# XTWO X2-212/90

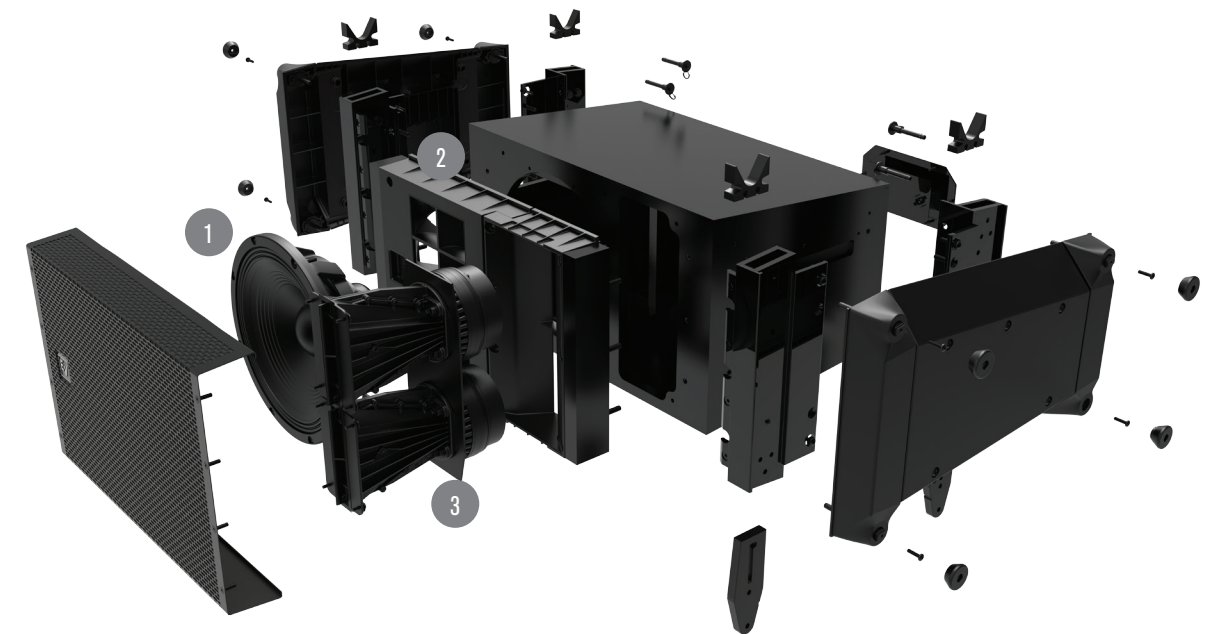

The X2-212/90 system provides high SPL capability, extended HF response, and linear LF output for more performance than previously possible from an extremely compact cabinet.

The X2 is a two-way vertical line-array loudspeaker that achieves directional control that is similar to the X1, but delivers even more output, lower distortion, and wider bandwidth from the same compact form factor.

The advanced acoustical and mechanical designs of X2, combined with LAPS 3, provide the tools and flexibility to easily design and deploy high-performance vertical line-array systems.

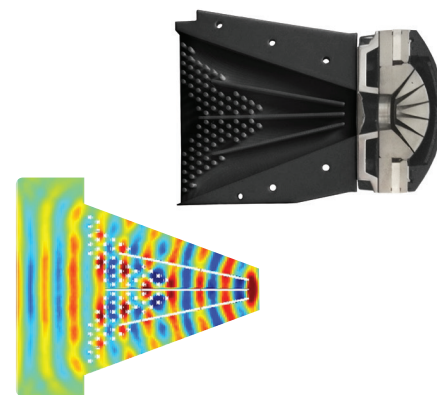

### X2 Plane-Wave Creation

The state-of-the-art X2 Pin Diffraction Hydra (PDH) delivers a flatter, more uniform wavefront and extends the linear HF output beyond 19 kHz. As the acoustic wave exits the ND6A driver and travels through the Hydra, the pins shape the wavefront so the resulting output is a uniformly shaped wall of acoustic energy at virtually any frequency throughout the HF range. When combined with the latest generation ND6A 3" HF driver, this large-format HF section delivers performance unmatched on the market today.

SPECIFICATIONS	X2-212/90
Frequency Response (-3 dB):	52 Hz – 19 kHz
Horizontal Coverage:	90° horizontal
System Sensitivity:	101 dB (1 W/1 m)
LF Transducer:	12" DVN3125
HF Transducer:	Two 3" ND6A
Configuration:	Bi-amp only
Enclosure Material:	EVCoat-coated birch plywood
Dimensions (H x W x D):	13.5" x 28.5" x 21.125" (34.29 cm x 72.39 cm x 53.66 cm)
Net Weight:	93 lbs (42.18 kg)



### 1 DVN3125 Neodymium Woofer

For low frequencies, the new, high-sensitivity DVN3125 woofer was developed using the latest Multiphysics software to optimize motor, suspension, and electrical design for very low distortion, high efficiency, and maximum intelligibility at high SPL. The DVN3125 is designed with optimized frequency response for line array performance.



### 2 Mid-Band Hydra (MBH)

The 12" DVN woofer in the X2 is coupled to an EV-exclusive MBH device that effectively emulates the acoustic behavior of a double line of four 3" point sources to deliver superior mid-band coupling of the array while maintaining the efficiency, power, and bandwidth of a 12" transducer.

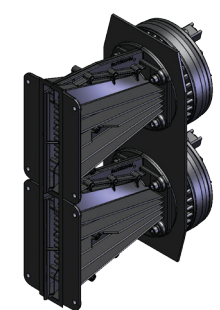

### 3 Pin Diffraction Hydra (PDH)

To satisfy the most demanding system applications, the HF section of the X2-212/90 matches two ND6A high-output 3" titanium compression drivers to a pair of advanced PDH constant-energy plane-wave generators on a constant-directivity waveguide. The advanced PDH provides full control of the acoustic wave, nearly eliminating wave distortion with in-phase summation beyond 19 kHz. All array elements sum seamlessly together to deliver consistent pattern control and smooth, extended, linear response for any array configuration.

# Subwoofer X12-128

# Subwoofer X12-128

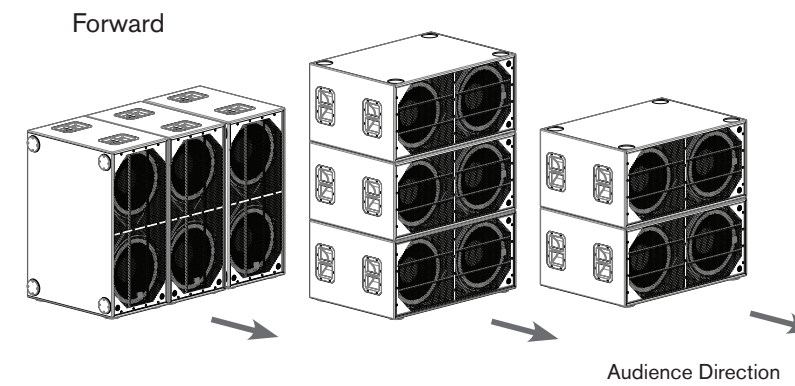

A broadside array is one in which a number of subwoofers are arranged in a row (or a row of stacked boxes), and the primary radiation is at right angles to the row. This is the typical sub arrangement seen in most stacked applications. In current practice, broadside arrays are overwhelmingly the most common form. The row might be straight, curved, or staircased.

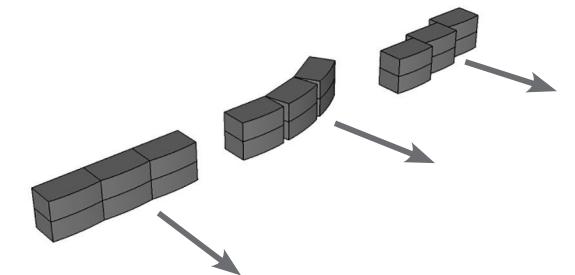

The X-Line Advance X12-128 subwoofer produces the greatest low-frequency impact and performance EV has ever developed.

Truly, the state of the art in subwoofer design, this compact cabinet delivers more LF output in a smaller footprint than other subs available today. In addition to its extremely high output capability, the X12-128 is designed to acoustically match seamlessly with any X-Line Advance top cabinet as a ground-stacked sub. It offers superior configuration flexibility for easier system design and setup, making it the standout sub choice for any larger-format live or installed audio application.

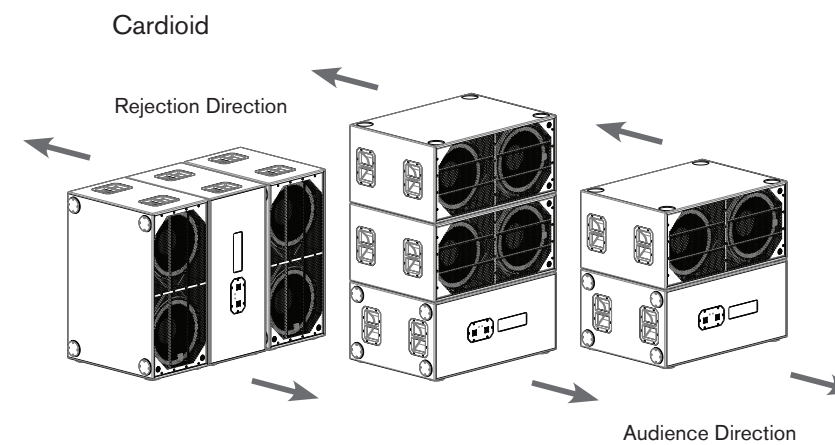

When front-firing and rear-firing loudspeakers are combined in a single array, such as EV's X12-128 in cardioid configuration, it is possible to develop advanced drive processing methods that optimize the acoustical output of the low frequency array to maintain a controlled directional pattern over the entire operating bandwidth of the subs. These cardioid settings use frequency-dependent delays (also called "all-pass filters") to offset the effects of sound propagation around the cabinets.

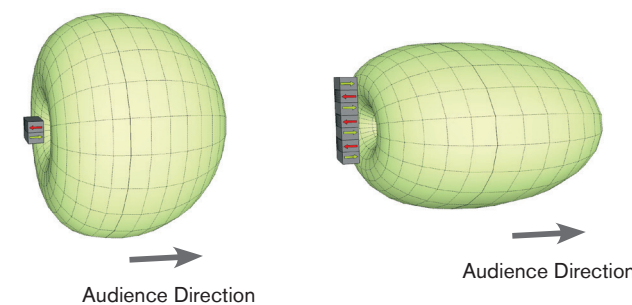

## SPECIFICATIONS

### X12-128

Frequency Response (-3 dB):	27 – 200 Hz
Horizontal Coverage:	Omni directional
System Sensitivity:	105 dB
LF Transducer:	2 x 18" DVF4180
HF Transducer:	NA
Configuration:	Parallel, dual
Enclosure Material:	EVCoat-coated birch plywood
Dimensions (H x W x D):	20.375" x 43.500" x 29.875" (51.75 cm x 110.49 cm x 75.88 cm)
Net Weight:	195 lbs (88.45 kg)

X-LINEADVANCE  
Rigging

X-LINEADVANCE  
Rigging

The IRS (Integrated Rigging System) on X1 and X2 was developed as a faster, safer way of flying, aiming, and landing a large vertical array.

The individual elements are fastened together by spring-loaded captive twist-lock pins. The captive twist-lock pins are located at each of the four upper corners and two lower front corners of each box. The upper pins attach each box to the extended link bars of the box above it to a grid. The pins are locked in their retracted (open) position by grasping each pin knob and pulling out as far as it will go, then turning the knob left or right to lock the pin. The link bars of the box or grid above can then be dropped safely into the V-blocks located at the top corners of the aluminum rigging. There is no fumbling for pin holes because the V-blocks are designed so that the bars will seat themselves in the correct position. Once seated, the pins are engaged by simply twisting each knob to unlock, allowing the spring to fire the pin into position. Lower front link bars are released or retracted and locked into position the same way. Rear link bars are set to the desired splay angle position with standard quick-release pins.

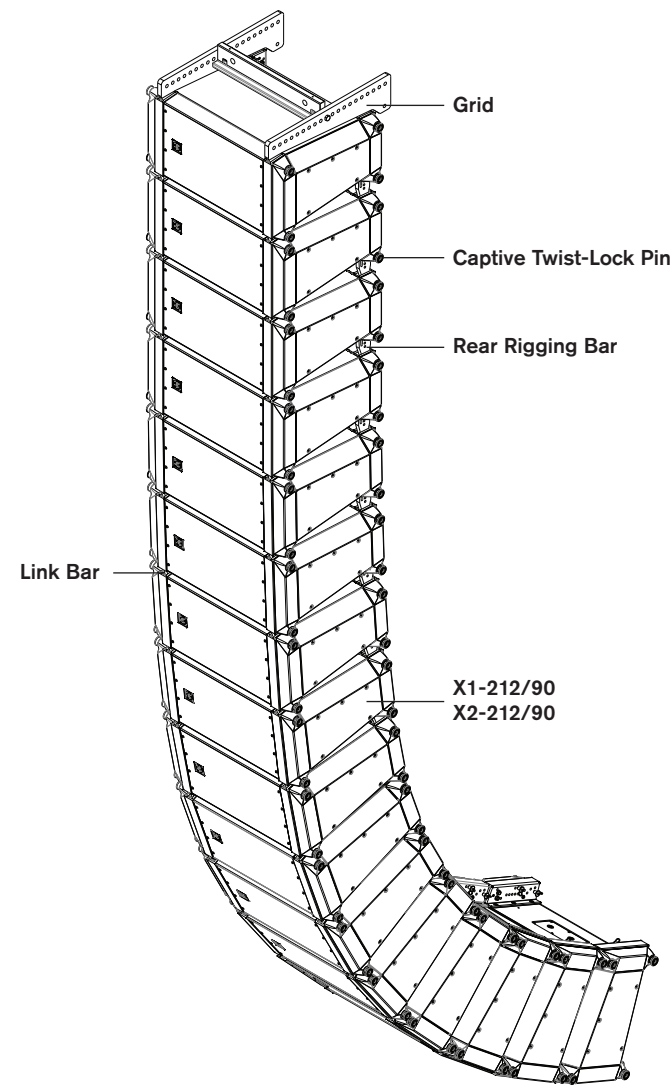

Captive Twist-Lock Pins

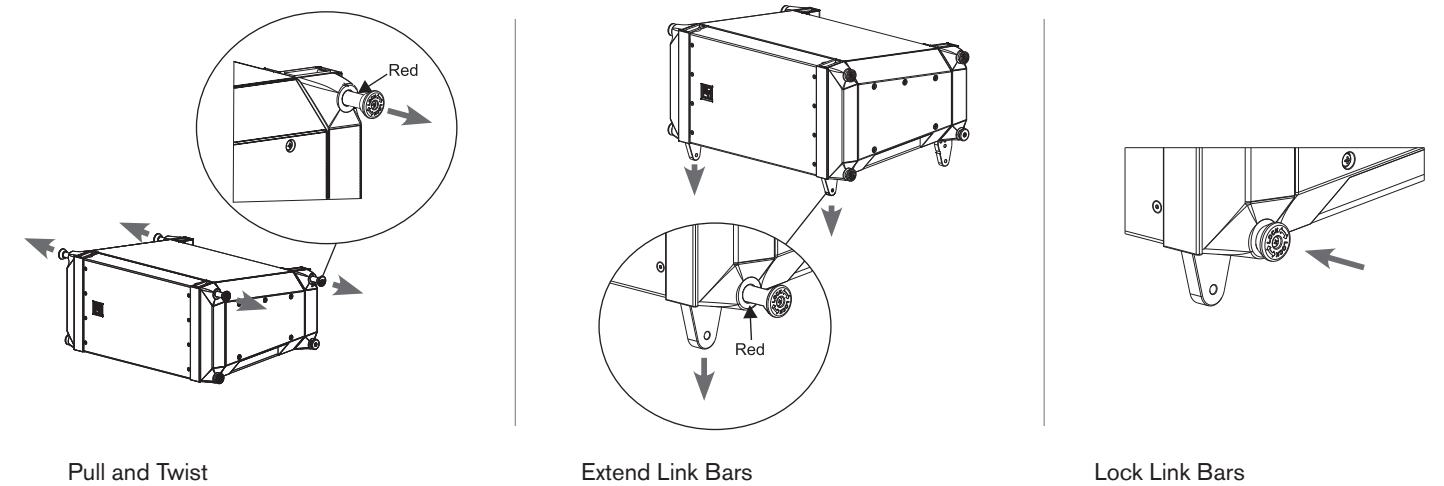

Pull and Twist

Extend Link Bars

Lock Link Bars

Splay Angle

The splay angle is selected by choosing corresponding holes in the white ANGLE SELECT sections of the rear rigging on each side (0°, 0.5°, 1°, 1.5°, 2°, 3°, 4°, 5°, 6°, 8°, 10°) as determined by LAPS 3. Unless the rigging is locked into a rigid configuration by secondary pins in the lower black ANGLE LOCK sections, the elements always default to 0° when lifted. Use of the bottom pull-up grid accessory enables the array to be easily compressed with each element stopping at its pre-selected splay angle. Smaller arrays may be rigidly pinned by lifting the rear of each box until it hits the pre-selected angle stop, then inserting a second pin per side into the appropriate hole in the ANGLE LOCK section. There is no fumbling for pin holes because when lifted the rigging will stop at the pre-selected position.

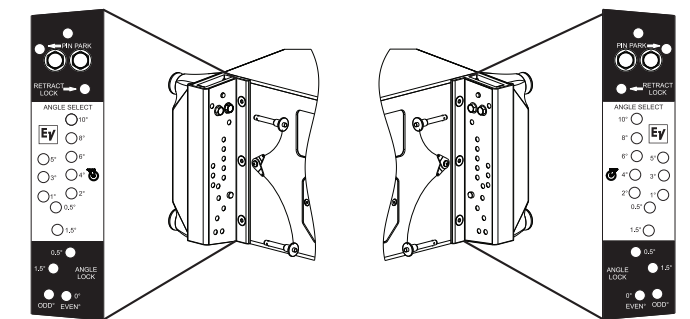

Rigging Hardware



# Grids and Rigging System

# Grids and Rigging System

## Choosing a Grid Configuration

Grid choice is determined by the top grid angle in combination with the number of elements in the array and the splay angle between them. To determine which grid model will achieve your desired angle as well as the safety factor for your system, use LAPS 3 to design your array and observe all warnings and limitation messages displayed by the software.

No matter how large the system hang, the rigging design of the X-Line Advance system provides for an extremely high safety factor in any installation.

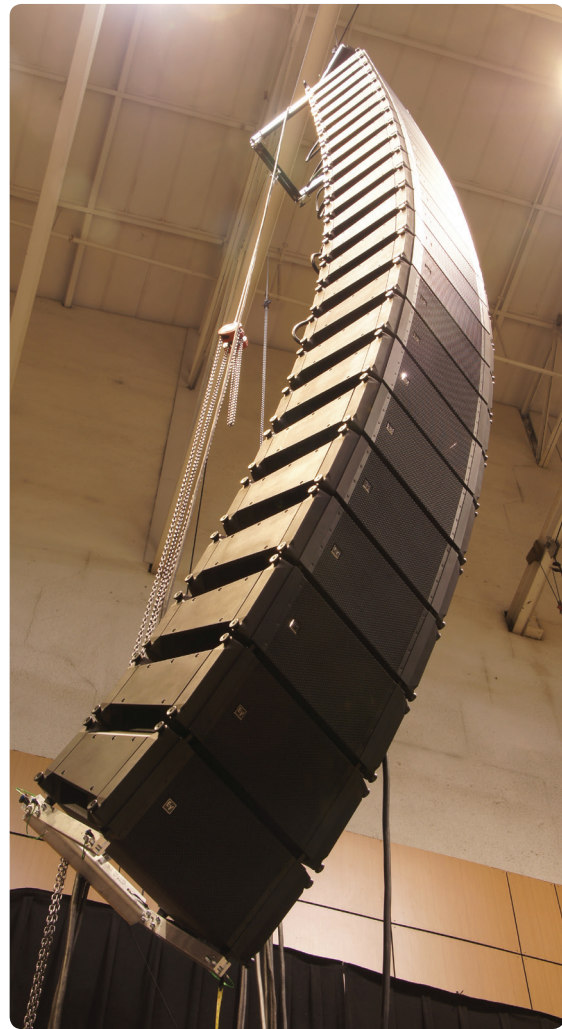

X12TC-GRID with pull-back to venue

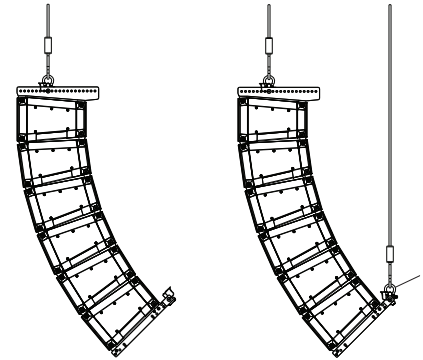

X12TE-GRID using X12PU-BGK to pull-up to grid

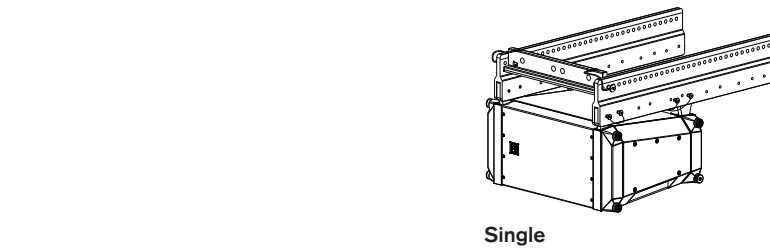
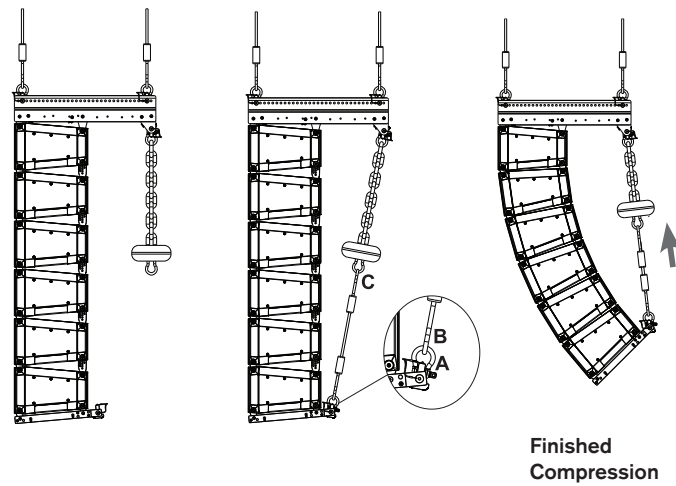

Single

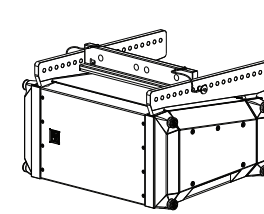
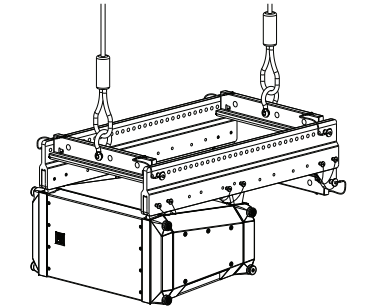

Forward

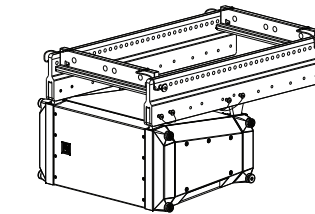

Double

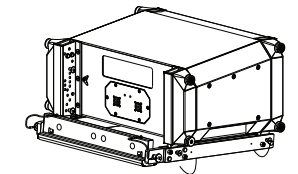

Pull-Up Kit Installed

## X12TC-GRID Compact Grid

The X12TC-GRID compact grids are appropriate for arrays that do not require extreme up or down angles. It is rated for a maximum hang of up to 24 X1 or X2 elements. Use LAPS 3 to determine if X12TC-GRID combined with the number of elements will achieve the acoustical coverage in the venue at a safe working load.

## X12TE-GRID Extended Grid

X12TE-GRID extended grid is available for flying arrays that require greater up or down angles than are possible with the X12TC-GRID compact grid. The front and rear link bars can be locked at three different locations along the side rails to facilitate the extreme up-angles sometimes required in venues with multiple high balconies. The additional length of the X12TE-GRID also enables more extreme down-angles from a single point than would otherwise be possible. Note that de-rating occurs as the angle becomes more extreme. Consult LAPS 3 for limitations in a particular array configuration. The X12TE-GRID is also required in order to use the X12PU-BGK pull-up grid to hang an array using the rear compression rigging method. The X12TE-GRID comes with two spreader bars to support two motors when the compression rigging method is used.

## X12PU-BGK Pull-Up Kit

X12PU-BGK pull-up kit is used with the compression rigging method or when extreme down angles beyond the capabilities of the extended grid are required. This is a way to achieve extreme down angles, such as those that might be encountered in a distributed arena system. When using one (1) X12TC-GRID and one (1) X12PU-BGK in this fashion, the angle between the suspension lines must never be allowed to exceed 30°. For maximum angles, restrictions and limitations, consult LAPS 3 and follow all warning, limitations and restrictions recommended by the software.

# Transport System

# Transport System

## Next Generation Transport Systems

The X-Line Advance transport system consists of innovative dollies for both the top boxes and the subwoofers. They provide a fast and convenient foundation to move X-Line Advance hardware from point A to B. Designed for quick rigging and disassembly, the transport dollies for the top boxes and the subs fit neatly into a variety of cargo containers and vehicles anywhere on the globe. The dollies quickly breakdown and store easily during a performance and can be quickly configured when the time comes to move the whole rig out. The efficient packing design of the system saves both transport space and cost.

X-Line Advance is designed to be transported in most common truck pack configurations, from local rental trucks and vans to large interstate and international trucks.

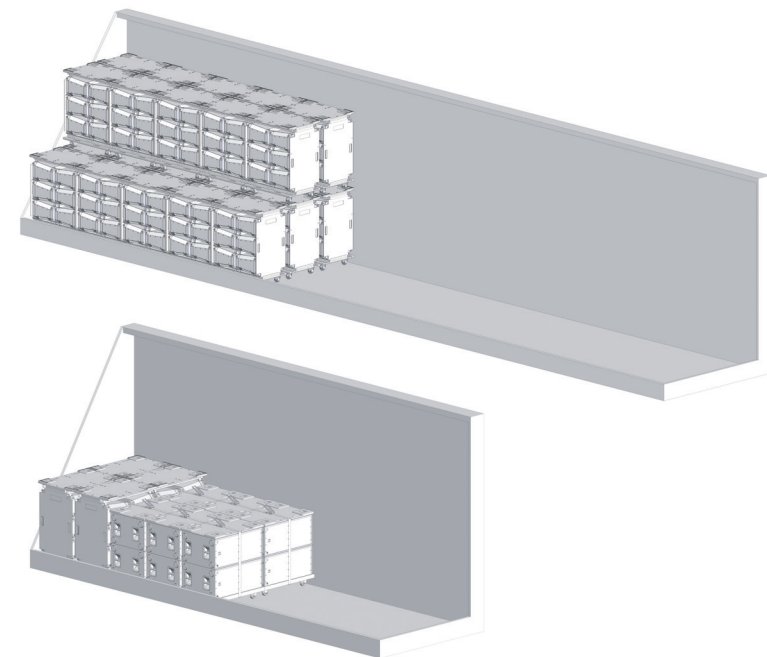

## Dollies

X12T-DOLLY is designed to transport six X1 or X2 loudspeakers in two stacks of three loudspeakers, with grille-protecting panels and a solid cover which functions to protect the loudspeaker during transportation, allowing an additional dolly to be stacked on top. The X12T-DOLLY top cover also doubles as the ground-stack kit for up to six X1 or X2 loudspeakers.

The X12-128-DOLLY is designed to carry two subwoofers in a single dolly, with a protective top cover and bumper rails to protect subs; it also includes a ratchet strap to prevent subs from moving. The design allows another sub dolly to be stacked securely on top.

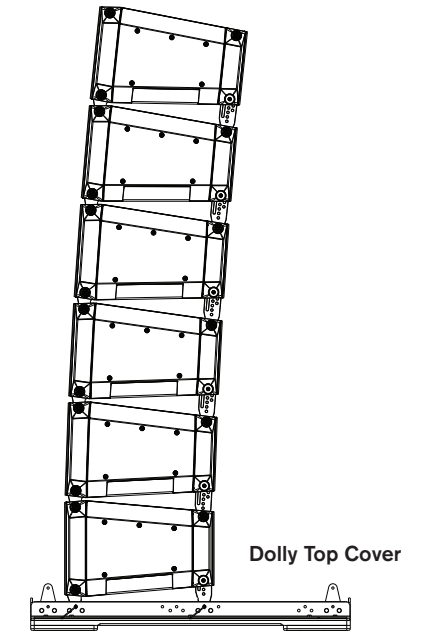

Dolly Top ground-stacking

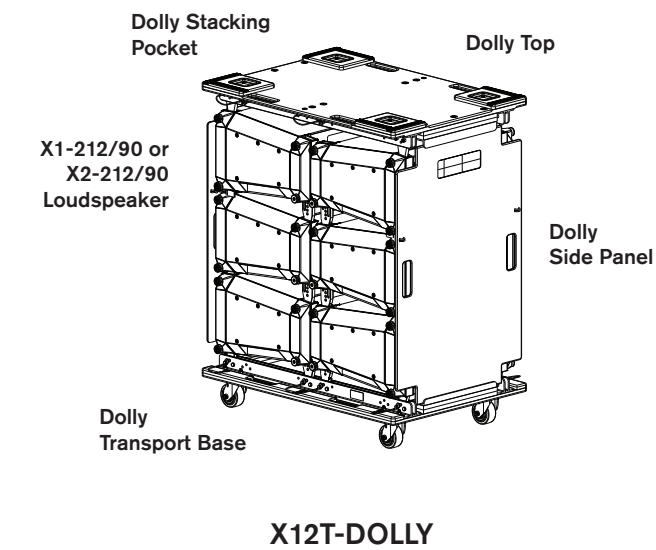

X12T-DOLLY

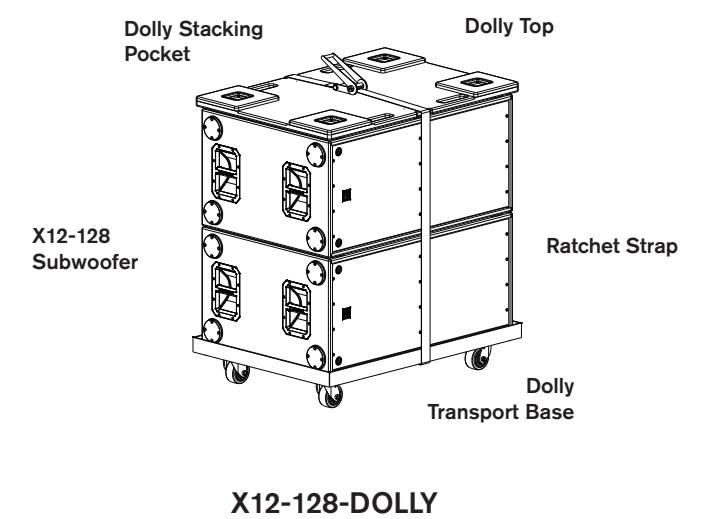

X12-128-DOLLY

# Line Array Prediction Software

# Line Array Prediction Software



## Line Array Prediction Software 3 (LAPS 3)

LAPS 3 software is based on a completely new acoustic and mechanical computation engine called the Optimizer. The Optimizer provides a number of benefits in LAPS 3, and will allow the addition of significant new functions in the future.

### Acoustics

LAPS 3 offers more accurate and detailed acoustical predictions than previous versions of the LAPS software. The Optimizer's predictions are based on full high-resolution measured loudspeaker data. The use of this data provides much more precise prediction results, especially in the high frequencies.

### Venue Page

POINTS	Rise, Feet	Run, Feet	Stage Specs, Feet
A	8.0	0.0	Depth: 0.0, Height: 0.0
B	60.0	2.5	Head Height, Feet: 0.0
C	108.0	9.0	4.0
D	80.0	18.0	0.0
E	118.0	22.5	0.0

### Air Loss Estimator

**AIR LOSS ESTIMATOR**

Air Pressure: 103125 Pa  
 Ambient Temperature: 68 F  
 Relative Humidity: 50 %  
 Frequencies: 3000, 500, 8000 Hz

Graph: Air Loss (dB) vs Distance (0 to 175)

### Full Accounting for Air Absorption

The Optimizer takes air absorption fully into account, to provide much more accurate prediction of far-field array performance in large venues.

### Loudspeaker Cable Loss Calculator

**LOUDSPEAKER CABLE LOSS CALCULATOR**

**PARAMETERS** (enter numbers here)

AMPLIFIER RATINGS  
 Output: 2000 Watts  
 Output rated into: 8 Ohms  
 Damping factor: 400

LOUDSPEAKER RATING  
 Impedance: 8 Ohms

**RESULTS**

Net power loss due to cable: 0.3 dB  
 Effective damping factor: 25.1  
 Power to loudspeaker: 1859 Watts  
 Roll-off frequency (-3dB) due to capacitance: 2557 kHz  
 Full-power voltage to loudspeaker: 121.8 Volts  
 Full-power current through loudspeaker: 16.2 Amperes  
 Total round-trip resistance of 150.0 ft cable: 0.30 Ohms

### Array Main

Model	Inclin	Drive	Drive Level	Pinhole or Note
1 XT12C-Grid-F	-4.5°	4	0.0 dB	0"
2 X2	-4.5°	4	-0.0 dB	1.5"
3 X2	-6.0°	1	0.0 dB	1.5"
4 X2	-7.5°	1	0.0 dB	2"
5 X2	-9.5°	1	0.0 dB	2"
6 X2	-11.5°	2	-2.0 dB	4"
7 X2	-13.5°	2	-2.0 dB	6"
8 X2	-21.5°	2	-2.0 dB	8"
9 X2	-29.5°	3	-4.0 dB	10"
10 X2	-39.5°	3	-4.0 dB	10"
11 X2	-49.5°	4	-8.0 dB	10"

## Mechanics

The new X-Line Advance line-array loudspeaker family has a mechanically advanced rigging system that provides smoothly curved arrays at all angles. LAPS 3 fully supports this.

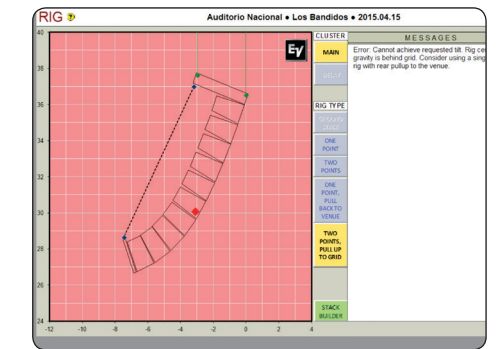
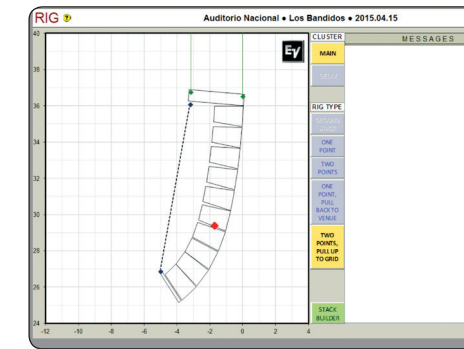
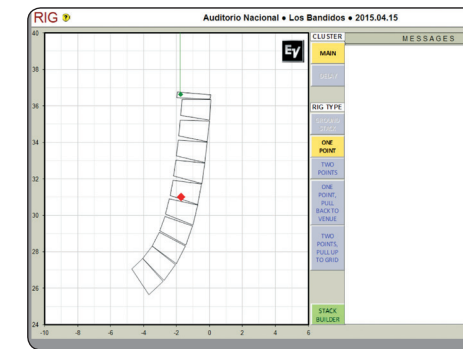

### Improved RigPic

The RigPic has been upgraded to show the new features. It now also provides clearer indication of "unriggable" configurations as well, i.e. configurations that fail load-limit tests or otherwise should not be used.

### Support for Pullback-to-grid Arrays

The X-Line Advance family supports a new rigging mode in which a tension cable attached to the rear of the grid is used to pull the array into the desired arc. LAPS 3 fully supports this.

### Improved Diagnostic Messages

LAPS 3 rigging diagnostic messages have been made clearer and more informative.

**RIGGING SAFETY FACTOR**

10:1

Click to choose colors for selected box(es)

### Selectable Rigging Safety Factor

The LAPS 3 Preferences page now allows the rigging load safety factor to be set to 8:1, 10:1, or 12:1, to accommodate differences in local regulations. The chosen safety factor is used in all array load-limit checks.

**RigReport**

VENUE: Auditorio Nacional  
 JOB: Los Bandidos  
 DESIGNER: G.Wabi  
 REV: 1  
 DATE: 2015.04.15

Working load safety factor: 10.0:1

**Main Cluster**

**Flypoint**

Point No.	Type	Distance	Load, lb	Pinhole or Note
1	Rigpoint 1	1.78	962	19

Grid Tilt: 4.5 degrees down  
 Elevations above Floor: Rig top: 36.76 ft, bottom: 25.65 ft  
 Height of rig: 11.11 ft  
 Frontmost point of rig: 0.10 ft downstage  
 Rearmost point of rig: 4.71 ft upstage

**Main Loudspeaker Rig Elements**

No.	Model	Inclin	Drive	Drive Level	Pinhole or Note
1	XT12C-Grid-F	-4.5°	4	0.0 dB	0"
2	X2	-4.5°	4	-0.0 dB	1.5"
3	X2	-6.0°	1	0.0 dB	1.5"
4	X2	-7.5°	1	0.0 dB	2"
5	X2	-9.5°	1	0.0 dB	2"
6	X2	-11.5°	2	-2.0 dB	4"
7	X2	-13.5°	2	-2.0 dB	6"
8	X2	-21.5°	2	-2.0 dB	8"
9	X2	-29.5°	3	-4.0 dB	10"
10	X2	-39.5°	3	-4.0 dB	10"
11	X2	-49.5°	4	-8.0 dB	10"

Delay cluster not selected or has no elements.  
 Box inclination angle = tilt angle of loudspeaker enclosure rear panel.

### Improved RigReport

The RigReport has been upgraded to be clearer and more compact, and to support the new features noted on this page.

### Better Product Upgrades Support

LAPS 3 and its successors allow separate distributions of software and product data. In the future, users will be able to download and install LAPS data for new products without having to install new versions of the LAPS 3 software.

**X-Line Advance brings a system approach to the market**, with DSP and amplification requirements to maximize system performance. The combination of IRIS-NET and OMNEO provide total system control, monitoring, and signal transport in one network. Multiple layers of back-up and redundancy make X-Line Advance a powerful system management and control solution for the permanent installation and live sound markets.

### X1 Compatible Amplifiers

Amplification choices for X1 systems have been formatted for complete flexibility to match system configurations from small installations to full capability for large live sound venues.



TG-7<sup>1</sup>



TG-5<sup>2</sup>

<sup>1</sup> Maximum recommended three (3) elements in parallel for a 2.6 ohm load.

<sup>2</sup> Maximum recommended two (2) elements in parallel for a 4 ohm load.

### X1 Compatible Processors

Various choices of DSP are available to use with X1 loudspeakers. These processors allow for multiple system designs to match venues' acoustical needs and budgets.



CP4000S<sup>2</sup>



CP3000S<sup>2</sup>



CPS2.12<sup>2</sup>



CPS 4.10<sup>2</sup>



N8000-1500, N8000 NetMax digital matrix controller with DSP-2 extension card



Dx46 Loudspeaker Processor with FIR-Drive



RCM-28 OMNEO Network and DSP Module for Tour Grade Amplifiers



RCM-810 IRIS-Net remote control module for CPS Series Amplifiers

### X2 and X12 Compatible Amplifier

Amplification choices for X2 systems have been configured to match systems for installation venues and live sound, available as pre-configured packages for cross-rental and system expandability with common network topology recommendations. These packages maintain common system performance and tonality between venues and stages.



TG-7<sup>1</sup>

<sup>1</sup> Maximum recommended three (3) elements in parallel for a 2.6 ohm load.

### X2 Compatible Processors

X2 systems require a common DSP platform for system commonality in DSP and acoustical performance, from venue to venue. NetMax and the RCM-28 together efficiently integrate the signal chain. They take over the function of a common system access point for DANTE/OMNEO, AES/EBU, and PC Ethernet, linking system control with signal routing and distribution across the entire system.



N8000-1500, N8000 NetMax digital matrix controller with DSP-2 extension card



RCM-28 OMNEO Network and DSP Module for Tour Grade Amplifiers

# IRIS-NET

## The First Comprehensive Audio Control Solution from Front to Back.

From the introduction of the first IRIS (Intelligent Remote Integrated Supervision) software platform for amplifiers in 2002, Electro-Voice has been developing a robust audio control protocol and new innovative audio hardware. The first was the RL line of remote controlled amplifier products. These amplifiers offered an amazing level of user control and monitoring, which brought reliability and ease of use to a wide range of users. EV's NetMax N8000 digital audio system controller, together with the advanced RCM-28 DSP module for TG amplifiers, delivers a robust Ethernet compatible digital link in the IRIS-Net audio processing chain.

IRIS-Net is EV's answer to the ever-increasing complexity of audio system designs. It is a comprehensive software platform, which encompasses a huge array of control options. All aspects of the audio chain are under its supervision and control. The key areas of signal processing, supervision and signal routing are all manipulated under its shell.

The NetMax N8000 with the RCM-28 is the central player in the IRIS-Net solution. It offers an extremely flexible hardware platform that allows for field level customization of the unit to nearly any application. This customization goes far beyond what is available today from other platforms.

Everything from the matrix size and configuration to the processing power can be customized in the field, making it easy to design the best solution value for the customer.

### OMNEO

Developed by EV's parent company Bosch, OMNEO media networking architecture allows the transport and easy control of audio, video, and other data over IP networks, satisfying the highest levels of both sound quality and synchronization whilst ensuring the lowest levels of latency – all in a highly reliable and secure set up. The use of standard IT components keeps installation, maintenance, and overall system costs competitively low.

OMNEO is based on two key technologies – the media transmission component Dante™ and the system-control component OCA (Open Control Architecture) – and is enhanced by Bosch-specific features. OMNEO provides highest interoperability, flexibility, reliability, and future-proof technology by utilizing open public standards. Additionally, OMNEO comes with specific advanced features to even



allow for mission-critical and life safety system applications. The technology provides a number of options for the interconnection of equipment from different manufacturers, and also those outside of traditional audio or intercom applications. An OMNEO media-networking architecture can be scaled to include up to 10,000 nodes and can interoperate across multiple IP subnets and long distances for complex network designs and applications.

### FIR-Drive

FIR-Drive is a combination of DSP and other EV technologies that come together to create a sophisticated loudspeaker correction and protection system. EV DSP, loudspeaker, and application engineers have been working together on this new technology for many years now, and have been constantly improving the technology with firmware, software, and speaker settings updates. The technology is modular and modules can be added to the package for further functionality. FIR-Drive has allowed EV engineers to improve and correct loudspeakers in ways unimaginable only a few years ago.

Proprietary to EV, the technology requires both software and hardware components to work at its maximum potential. EV has a number of loudspeaker management controllers that support the implementation at a variety of price points. Different styles of processors are available to meet the needs of any company or application.

# IRIS-NET

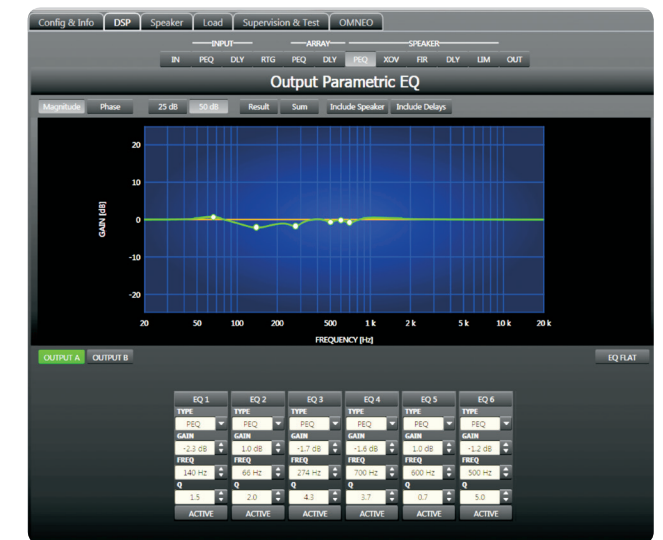
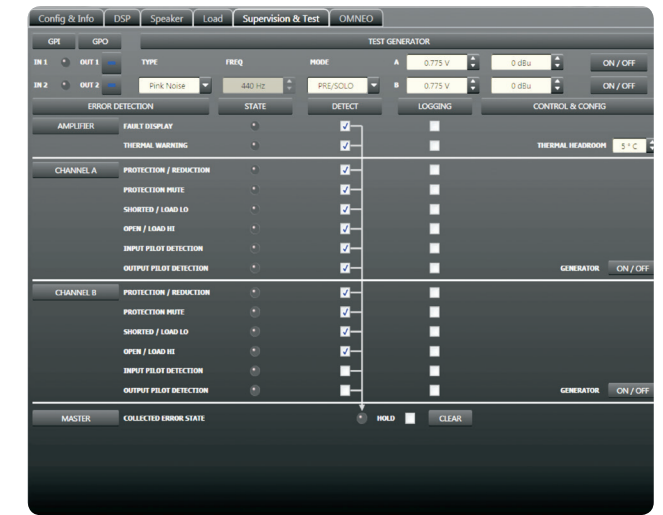
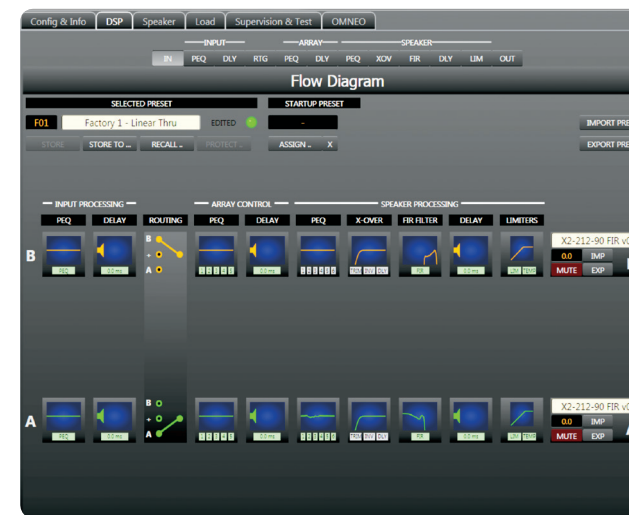

# X-LINE Configurations

# X-LINE Configurations

## X1 Passive Quarter System

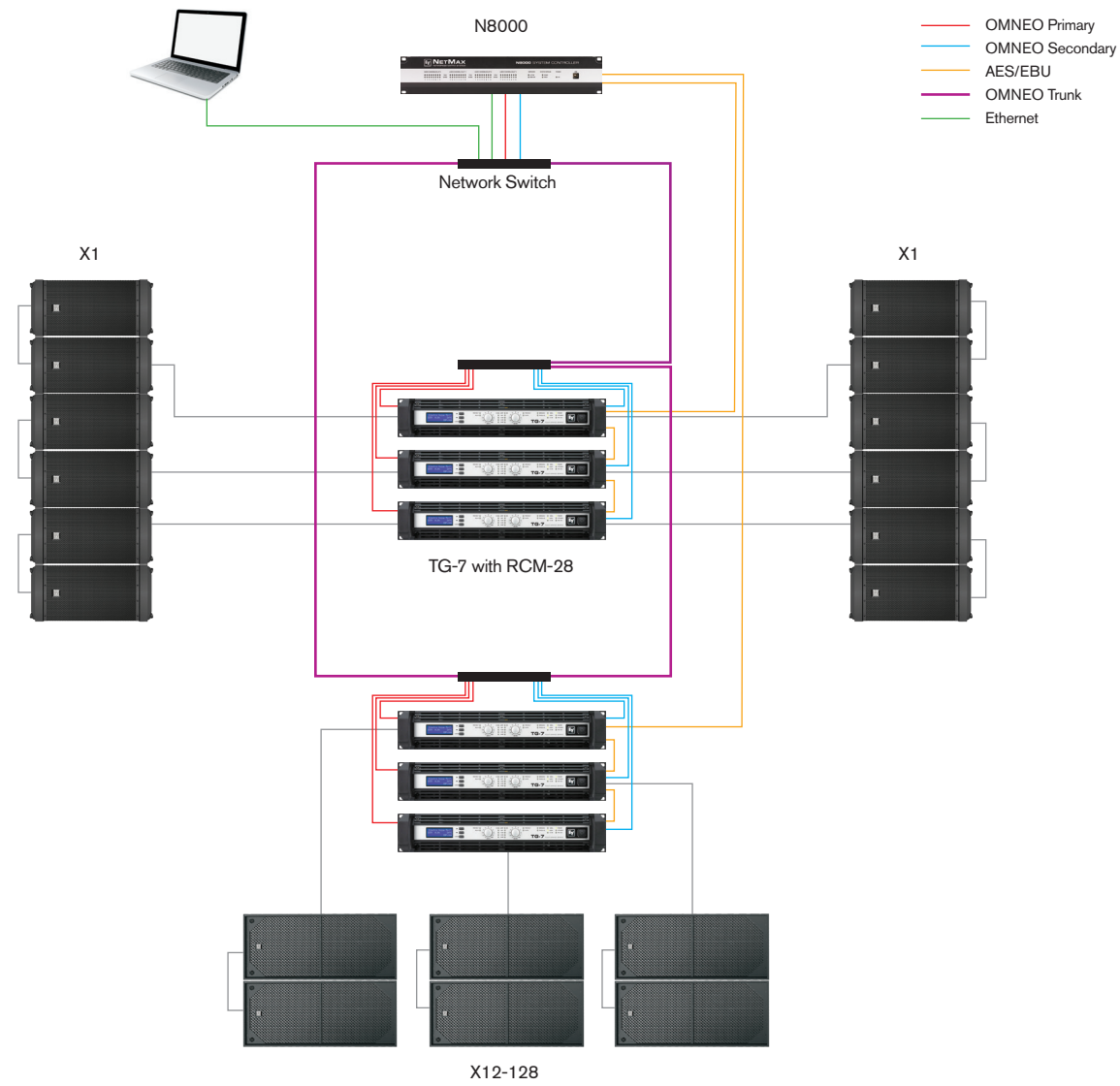

## X1 or X2 Bi-amp Quarter System

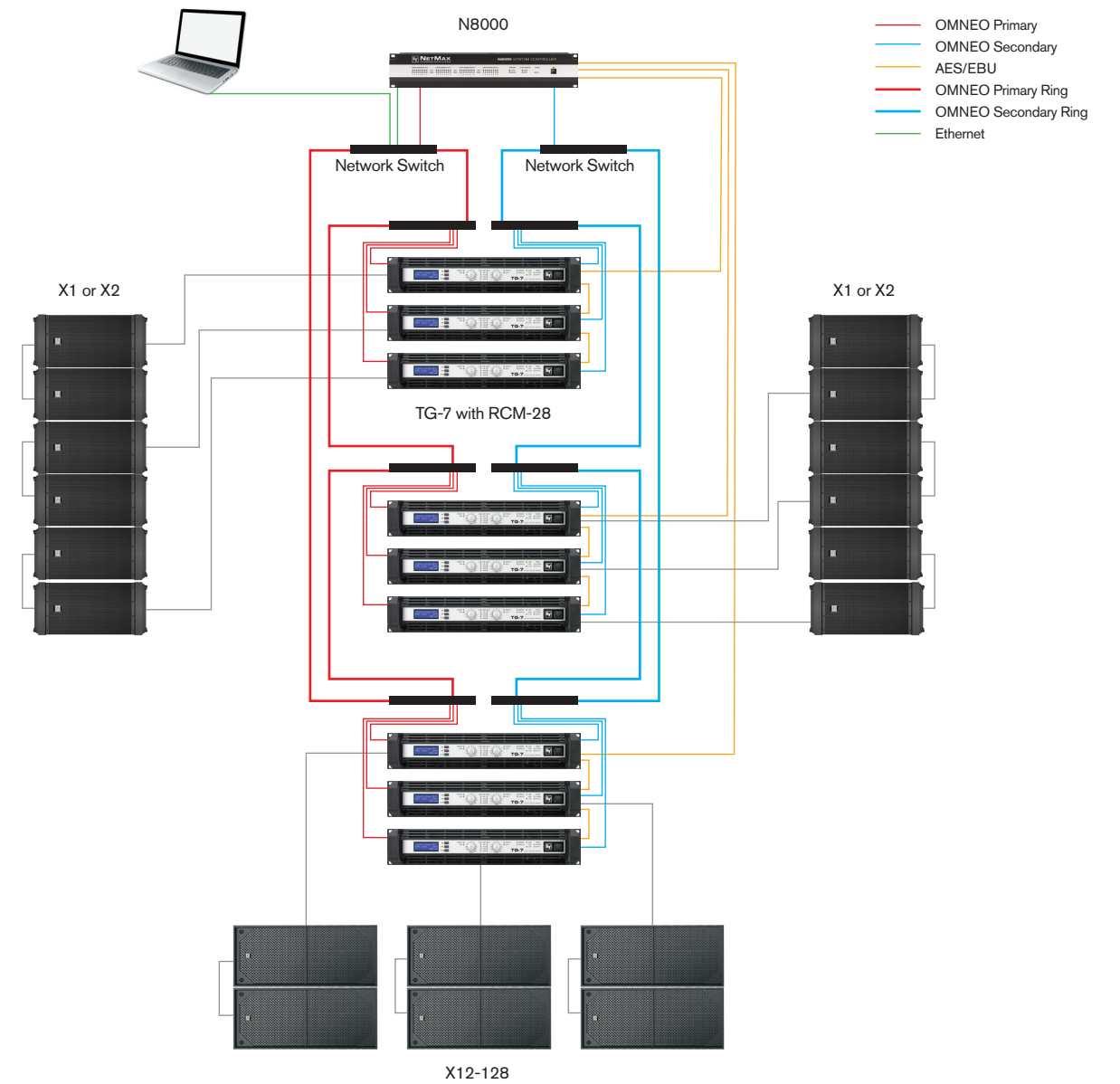

System configurations listed in this guide, are recommendations on how to set-up a Glitch-Free topology network. This will allow for multiple layers of redundancy through OMNEO, by using OMNEO-Primary, OMNEO-Primary ring, OMNEO Secondary, OMNEO Secondary ring and AES/EBU back-up. Through our OMNEO network, you will have audio and control in the same wire, knowing you will have multiple layers of redundancy not just in your audio chain, but also system control. If you choose, you may also run and set-up an additional layer of redundancy with an analog signal distribution directly to our TG7 amplifiers, creating six avenues for signal to be present at all times. In order to prevent a major network failure, make sure audio mixer is set-up to Glitch Free or to whichever topology the audio network is built in, if not, network will collapse and it will require resetting.

# X-LINE Configurations

# X-LINE Configurations

### X1 or X2 Quarter System with TOPS Expansion Kit

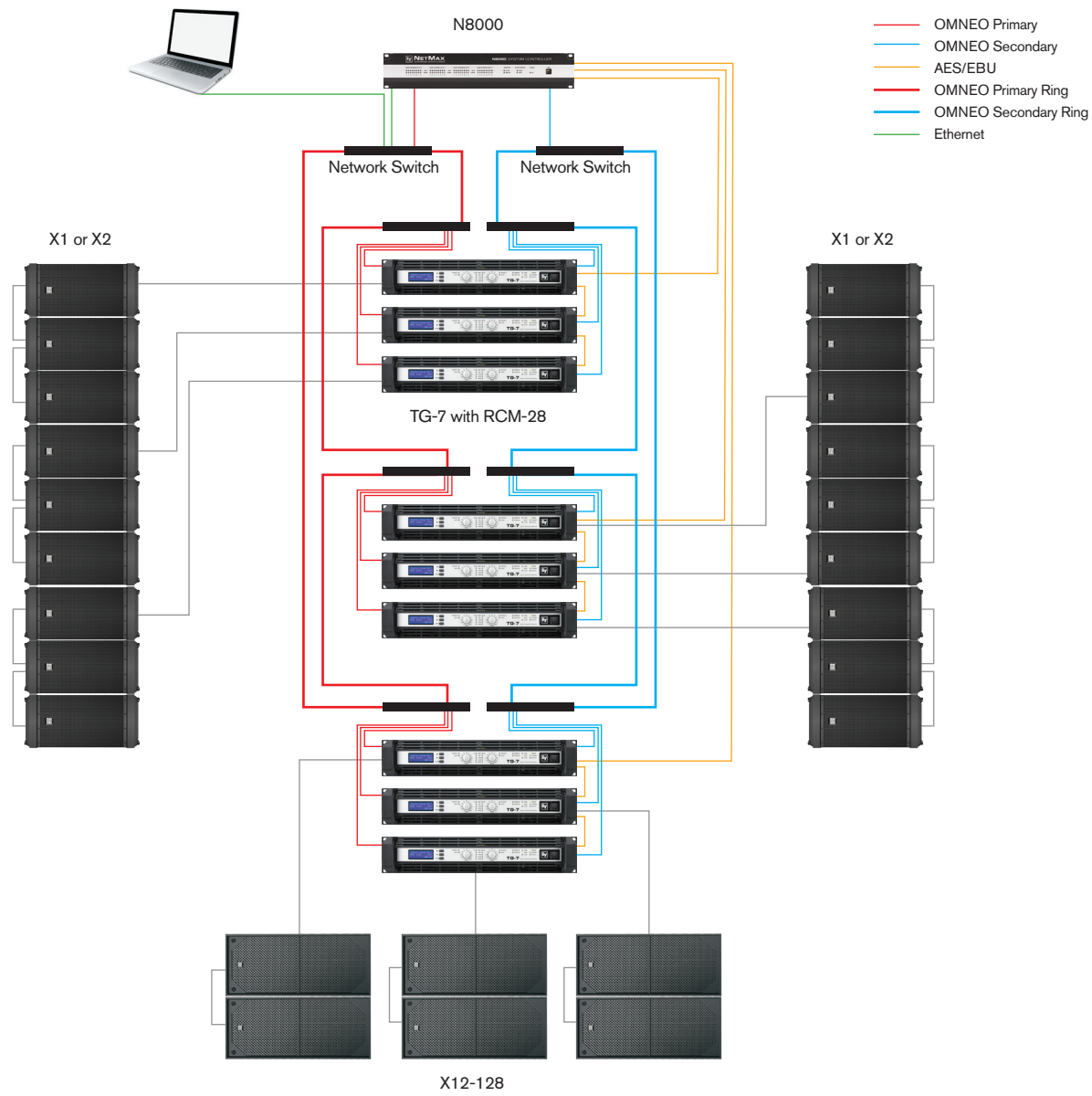

### X1 or X2 Bi-amp Half System

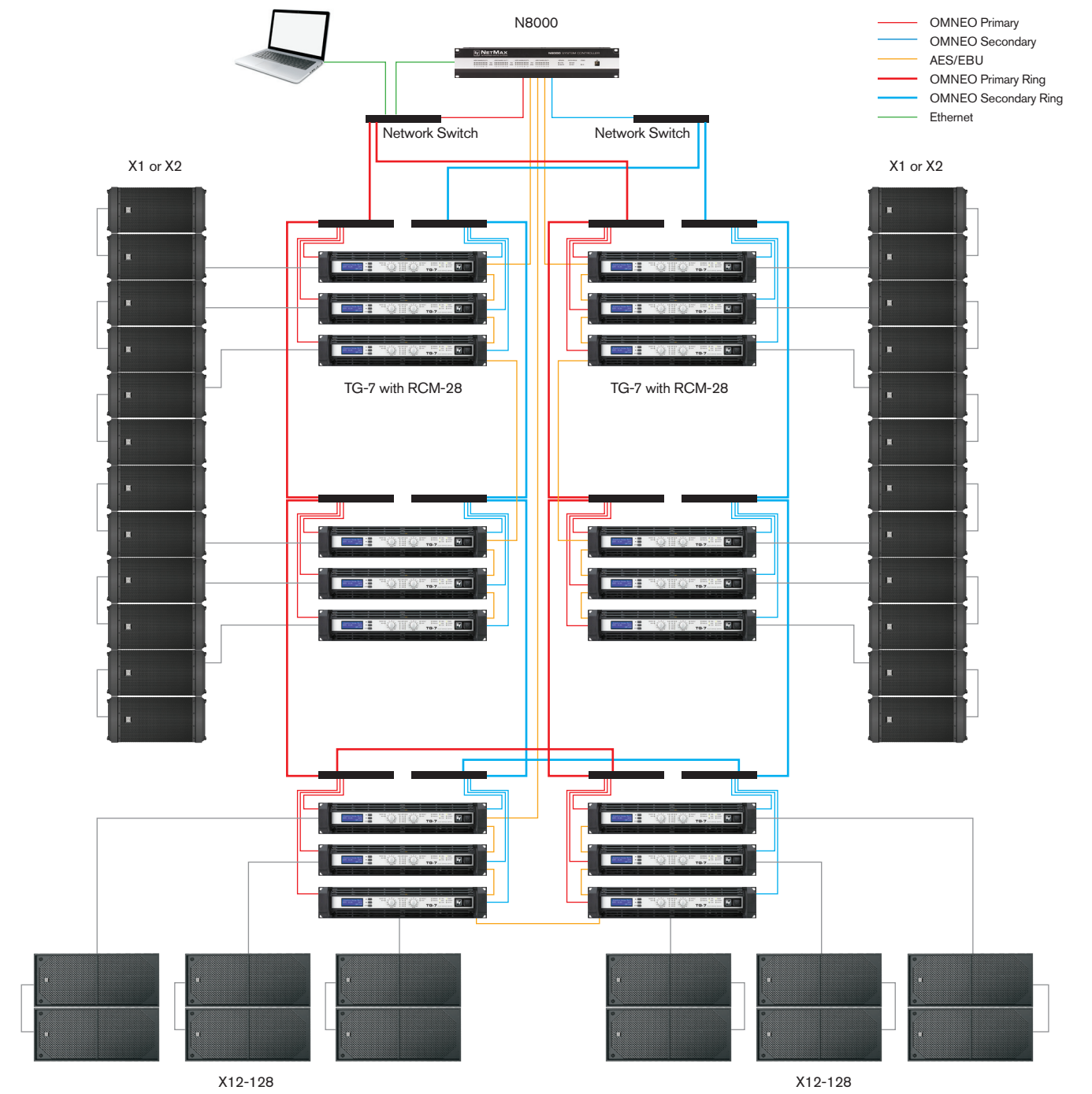

# X-LINE Configurations

## X1 or X2 Bi-amp Three Quarter System

- OMNEO Primary
- OMNEO Secondary
- AES/EBU
- OMNEO Primary Ring
- OMNEO Secondary Ring
- Ethernet

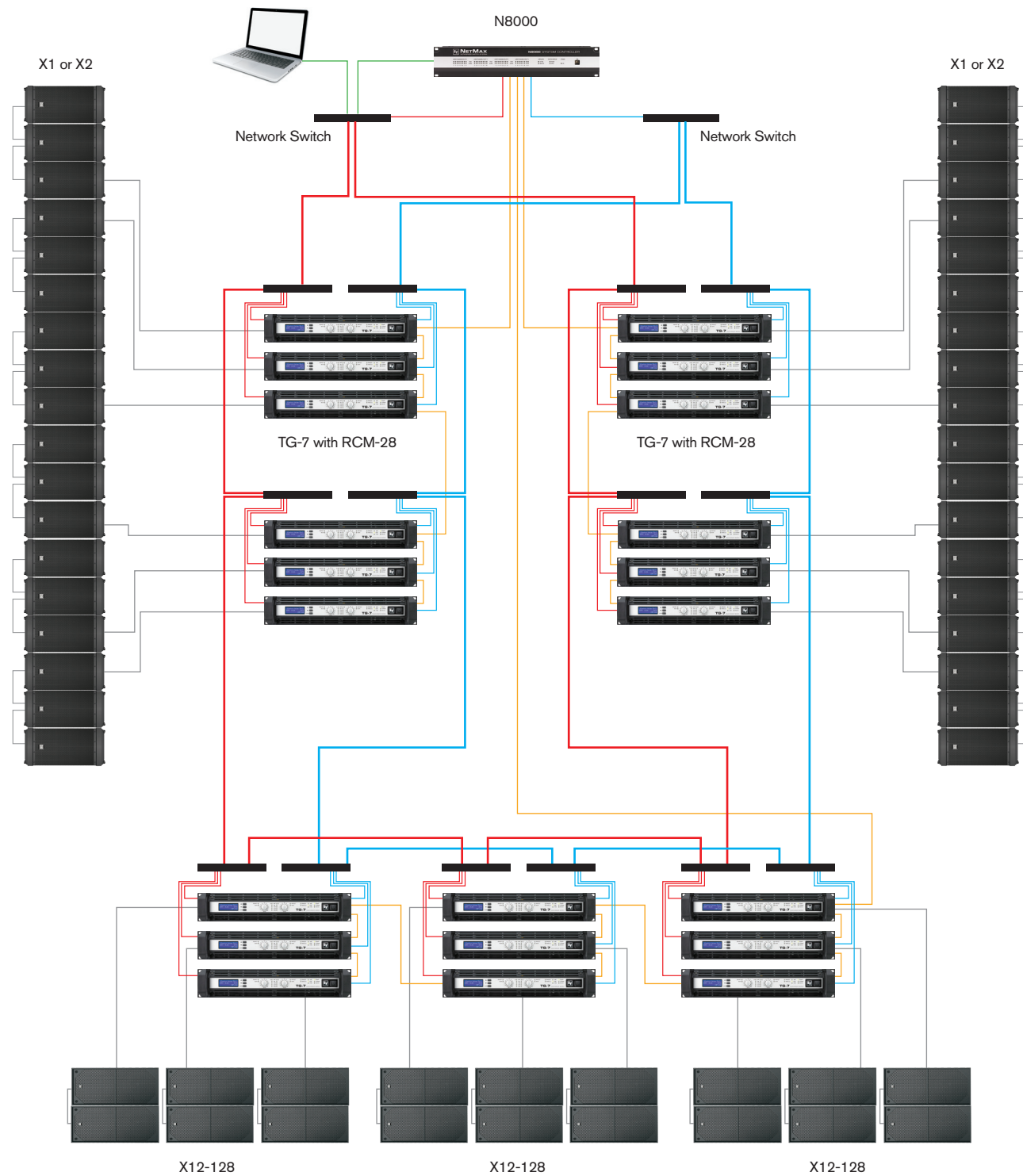

# X-LINE Configurations

## X1 or X2 Bi-amp Full System

- OMNEO Primary
- OMNEO Secondary
- AES/EBU
- OMNEO Primary Ring
- OMNEO Secondary Ring
- Ethernet

